

AS 400 Series

Patina™



## ASDV 255 Clean Room Suitable for Class 1 - 3

Can be used in a variety of areas ranging from pharmaceuticals to precision engineering and dust laden areas.

This totally sealed luminaire combines safety with functionality.

### Features

- Material: Zintec steel powder-coated
- IP 65 rated
- Reflectors: patented design in Alanod Miro 4 material
- Removable gear tray; complete with 4 pole plug
- Fits into a 1200 x 600 frame, can be surface mounted.
- Diffuser: UV-stabilised polycarbonate
- Optical integrated Dali programmable sensor providing daylight dimming and / or occupancy
- Emergency option available

**Photometrics available on request**



## Specification

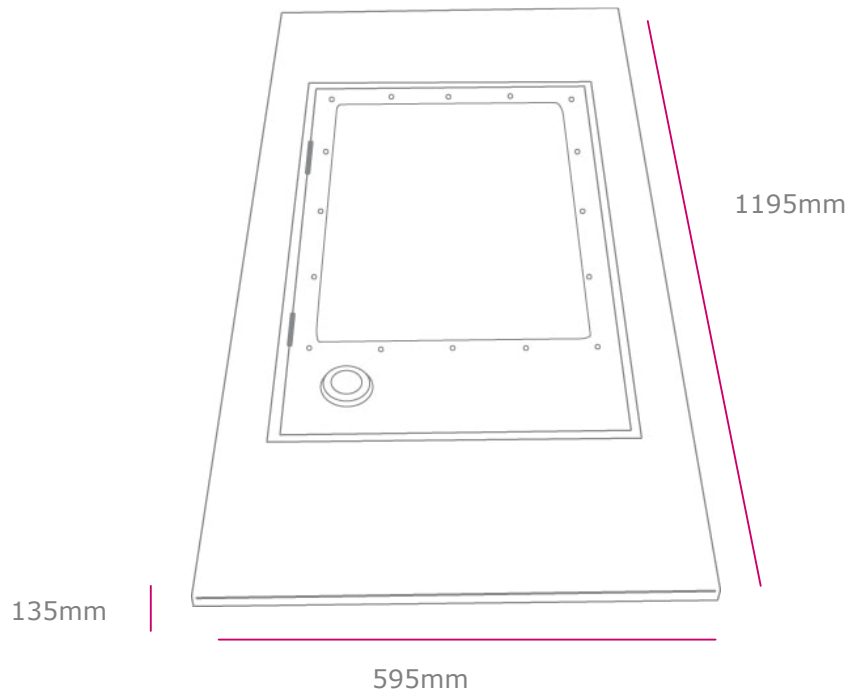

## Clean room Technical Data

Rated Mains Voltage	220....240V
Voltage Range (AC)	198....264V
Mains Frequency	0, 50....60 Hz
Power factor	$\lambda = 0,99$
Temperature range	0°C up to +40°C
Power Consumption	120 Watts
Standard	EN 60598 Part 1 & 2
Dimensions	(L) 1195mm (W) 595mm (D) 135mm

- Patina™ is constantly developing its products. The right is reserved to change specifications without prior notification or public announcement.